

RG Series

High Rigidity Roller Type

RGW-CC / RGW-HC

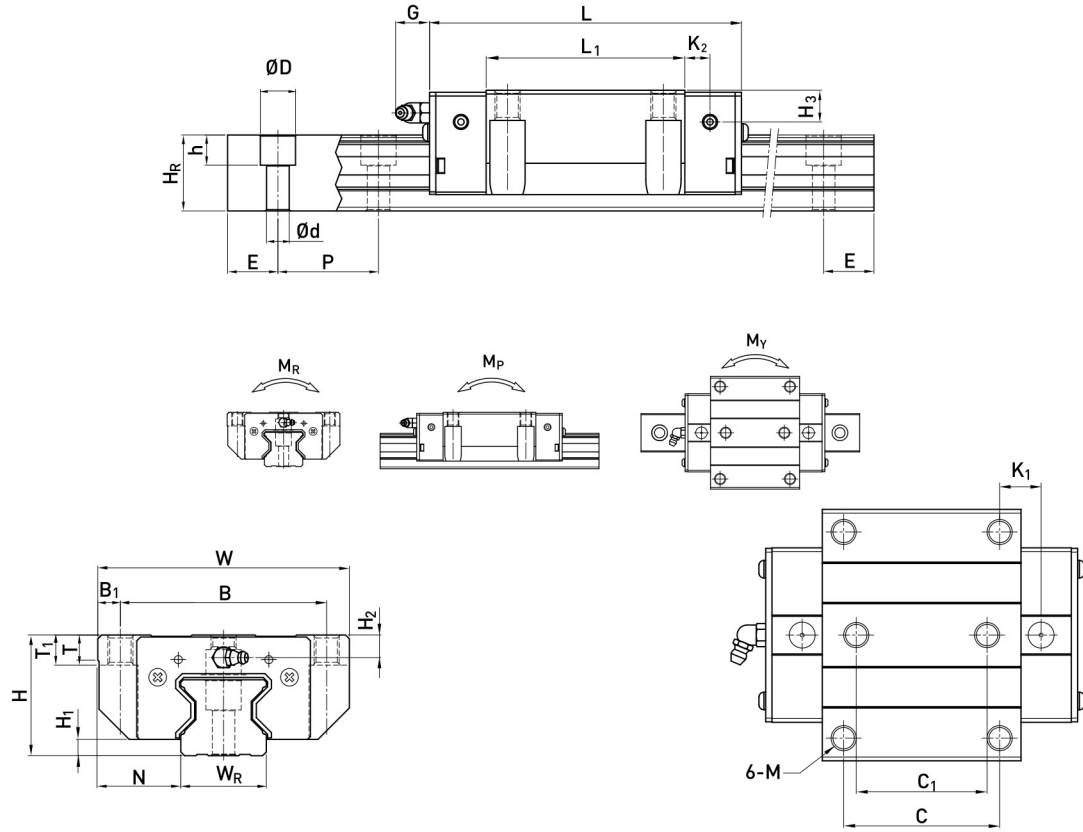

Model No.	Dimensions of Assembly (mm)			Dimensions of Block (mm)													Dimensions of Rail (mm)										Mounting Bolt for Rail (mm)	Basic Dynamic Load Rating C(kN)	Basic Static Load Rating C ₀ (kN)	Static Rated Moment			Weight	
																														M _R	M _P	M _Y	Block	Rail
	H	H ₁	N	W	B	B ₁	C	C ₁	L ₁	L	K ₁	K ₂	G	M	T	T ₁	H ₂	H ₃	W _R	H _R	D	h	d	P	E	C _R (kN-m)				C _P (kN-m)	C _Y (kN-m)	kg	kg/m	
RGW15CC	24	4	16	47	38	4.5	30	26	45	68	11.4	4.7	5.3	M5	6	6.95	3.6	6.1	15	16.5	7.5	5.7	4.5	30	20	M4x16	11.3	24	0.311	0.173	0.173	0.22	1.8	
RGW20CC	30	5	21.5	63	53	5	40	35	57.5	86	13.8	6	5.3	M6	8	10	4.3	4.3	20	21	9.5	8.5	6	30	20	M5x20	21.3	46.7	0.647	0.46	0.46	0.47	2.76	
RGW20HC									77.5	106	23.8																26.9	63	0.872	0.837	0.837	0.63		
RGW25CC	36	5.5	23.5	70	57	6.5	45	40	64.5	97.9	15.75	7.25	12	M8	9.5	10	6.2	6	23	23.6	11	9	7	30	20	M6x20	27.7	57.1	0.758	0.605	0.605	0.72	3.08	
RGW25HC									81	114.4	24																33.9	73.4	0.975	0.991	0.991	0.91		
RGW30CC	42	6	31	90	72	9	52	44	71	109.8	17.5	8	12	M10	9.5	10	6.5	7.3	28	28	14	12	9	40	20	M8x25	39.1	82.1	1.445	1.06	1.06	1.16	4.41	
RGW30HC									93	131.8	28.5																48.1	105	1.846	1.712	1.712	1.52		
RGW35CC	48	6.5	33	100	82	9	62	52	79	124	16.5	10	12	M10	12	13	9	12.6	34	30.2	14	12	9	40	20	M8x25	57.9	105.2	2.17	1.44	1.44	1.75	6.06	
RGW35HC									106.5	151.5	30.25																73.1	142	2.93	2.6	2.6	2.40		

Note : 1. 1 kgf = 9.81 N

2. The theoretical dynamic rated load is C_{100R}, if necessary C_{50R} conversion formula is as follows : C_{50R} = 1.23 x C_{100R}